

DYNAPRO TIPMATIC SOFT-CLOSE

Full extension slide 40/70 kg



- Mechanical opening system for handle-free fronts
- Combines Tipmatic function with Soft-close damping
- Tool-free assembly of the Tipmatic Soft-close unit
- Can be used for Dynapro Soft-close full extension slides
- One unit for all nominal lengths and weight classes
- 3-stage adjustment of the opening force
- Wide trigger range due to synchronisation rod

Packaging unit (PU):

- 204 = 5 units in a cardboard box
- 207 = 10 units in a cardboard box
- 208 = 12 units in a cardboard box
- 210 = 15 units in a cardboard box
- 211 = 20 units in a cardboard box
- 213 = 25 units in a cardboard box
- 223 = 100 units in a cardboard box
- 233 = 200 units in a cardboard box
- 517 = 50 units in PE in a cardboard box
- 607 = 10 units in a cardboard box in a cardboard box

Note:

- Dynapro Tipmatic Soft-close can be used from nominal length (NL) 270

ORDER INFORMATION

1 Dynapro full extension slide Soft-close Set: One left, one right					
NL	40 kg		70 kg		
	Art.-no.	PU	Art.-no.	PU	
270	F130107793	204 211	-		
300	F130107796	204 211	-		
320	F130107799	204 211	-		
350	F130107802	204 211	-		
380	F130107805	204 211	-		
400	F130107808	204 211	-		
420	F130107811	204 211	-		
450	F130107814	204 210	F130107832	204	210
480	F130107817	204 210	-		
500	F130107820	204 210	F130107838	204	210
520	F130107823	204 210	F130107841	204	210
550	F130107826	204 210	F130107844	204	210
580	-		F130107847	204	208
600	F130107829	204 208	F130107850	204	208
650	-		F130107853	204	208
700*	-		F130107856	204	208
750*	-		F130107859	204	208

* Load capacity 50 kg

4 Synchronisation rod Single item: For cutting to length					
L	Art.-no.	PU			
952	F134109410	207			

Individual components			
Description	Art.-no.	PU	
Dynapro Tipmatic Soft-close unit Set: One left, one right	F134109324	213	
Dynapro Tipmatic Soft-close activator Set: One left, one right	F134109325	223	
Front locking device (1D) Set: One left, one right	F134101220	233	517
Front locking device (2D) Set: One left, one right	F134108949	233	
Adjustment adapter (1D) Set: One left, one right	F134108952	233	

2a Dynapro 3D-Set Front locking device (2D) and adjustment adapter (1D), one of each left/right					
Art.-no.	PU				
F134108956	517				

2b Dynapro 2D set Front locking device (1D) and adjustment adapter (1D), one of each left/right					
Art.-no.	PU				
F134117193	517				

3 Dynapro Tipmatic Soft-close Set: Unit and activator, one of each left/right					
Art.-no.	PU				
F134109323	607				

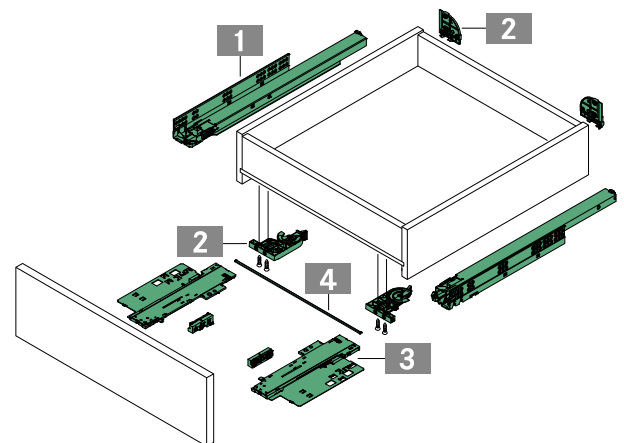

PAGE REFERENCES

Pull-out shelf	18	Assembly aids	24		
Technical information	20	Packaging code	75		

PLANNING DIMENSIONS

All dimensions in millimetres

Installation dimensions

Drawer

Inset drawer

	NL	SKL	MET
	270	260	273
	300	290	303
	320	310	323
	350	340	353
	380	370	383
	400	390	403
	420	410	423
	450	440	453
	480	470	483
	500	490	503
	520	510	523
	550	540	553
	580	570	583
	600	590	603
	650	640	653
	700	690	703
	750	740	753

Synchronisation rod cutting dimension

Locking device fixing position

Adjustment adapter fixing position

Position of the synchronisation rod

NL	A	B
270 - 320	248	265
350 - 750	283	300

Fixing positions for full extension slide

Euro screw \varnothing 6.3 x 14 mm
Chipboard screw \varnothing 4 x 16 mm
Screw head \varnothing 7 mm

LEGEND

HV Height adjustment	LWS Internal drawer width	SKL Length of drawer
KV Front edge of cabinet	MET Minimum installation depth	SV Side adjustment
L Length	NL Nominal length	
LWK Inside cabinet width	NV Tilt angle adjustment	